



GENERAL DESCRIPTION



The ICS8634-01 is a high performance 1-to-5 Differential-to-3.3V LVPECL Zero Delay Buffer and a member of the HiPerClockS™ family of High Performance Clock Solutions from ICS. The ICS8634-01 has two selectable clock inputs. The CLKx, nCLKx pair can accept most standard differential input levels. Utilizing one of the outputs as feedback to the PLL, output frequencies up to 700MHz can be regenerated with zero delay with respect to the input. Dual reference clock inputs support redundant clock or multiple reference applications.

FEATURES

- Five differential 3.3V LVPECL outputs
- Selectable differential clock inputs
- CLKx, nCLKx pair can accept the following differential input levels: LVPECL, LVDS, LVHSTL, HCSL, SSTL
- Output frequency range: 31.25MHz to 700MHz
- Input frequency range: 31.25MHz to 700MHz
- VCO range: 250MHz to 700MHz
- External feedback for “zero delay” clock regeneration
- Cycle-to-cycle jitter: 25ps (maximum)
- Output skew: 25ps (maximum)
- PLL reference zero delay: 50ps ± 100ps
- 3.3V operating supply
- 0°C to 70°C ambient operating temperature
- Lead-Free package available
- Industrial temperature information available upon request

BLOCK DIAGRAM

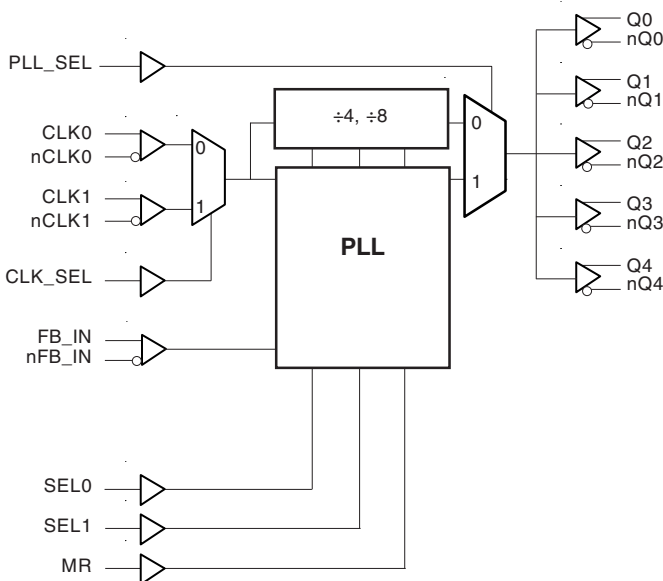

PIN ASSIGNMENT

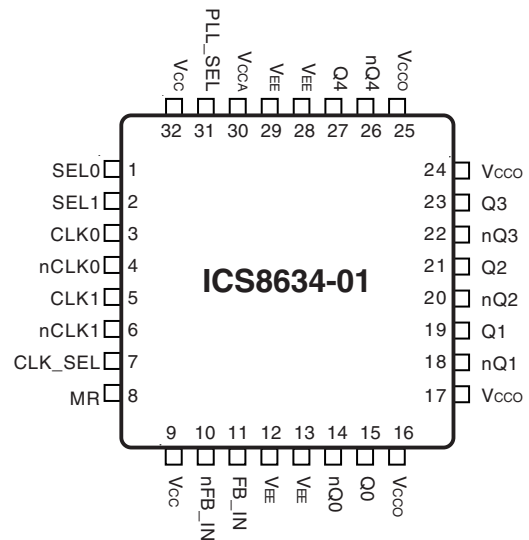

32-Lead LQFP

7mm x 7mm x 1.4mm package body

Y Package

Top View

32-Lead VFQFN

5mm x 5mm x 0.95mm package body

K Package

Top View



TABLE 1. PIN DESCRIPTIONS

Number	Name	Type		Description
1	SEL0	Input	Pulldown	Determines output divider values in Table 3. LVCMOS / LVTTTL interface levels.
2	SEL1	Input	Pulldown	Determines output divider values in Table 3. LVCMOS / LVTTTL interface levels.
3	CLK0	Input	Pulldown	Non-inverting differential clock input.
4	nCLK0	Input	Pullup	Inverting differential clock input.
5	CLK1	Input	Pulldown	Non-inverting differential clock input.
6	nCLK1	Input	Pullup	Inverting differential clock input.
7	CLK_SEL	Input	Pulldown	Clock select input. When LOW, selects CLK0, nCLK0. When HIGH, selects CLK1, nCLK1. LVCMOS / LVTTTL interface levels.
8	MR	Input	Pulldown	Active High Master Reset. When logic HIGH, the internal dividers are reset causing the true outputs Qx to go low and the inverted outputs nQx to go high. When logic LOW, the internal dividers and the outputs are enabled. LVCMOS / LVTTTL interface levels.
9, 32	V _{CC}	Power		Core supply pins.
10	nFB_IN	Input	Pullup	Feedback input to phase detector for regenerating clocks with "zero delay".
11	FB_IN	Input	Pulldown	Feedback input to phase detector for regenerating clocks with "zero delay".
12, 13 28, 29	V _{EE}	Power		Negative supply pins.
14, 15	nQ0, Q0	Output		Differential output pair. LVPECL interface levels.
16, 17, 24, 25	V _{CCO}	Power		Output supply pins.
18, 19	nQ1, Q1	Output		Differential output pair. LVPECL interface levels.
20, 21	nQ2, Q2	Output		Differential output pair. LVPECL interface levels.
22, 23	nQ3, Q3	Output		Differential output pair. LVPECL interface levels..
26, 27	nQ4, Q4	Output		Differential output pair. LVPECL interface levels.
30	V _{CCA}	Power		Analog supply pin.
31	PLL_SEL	Input	Pullup	Selects between the PLL and the reference clock as the input to the dividers. When HIGH, selects PLL. When LOW, selects reference clock. LVCMOS / LVTTTL interface levels.

NOTE: *Pullup* and *Pulldown* refer to internal input resistors. See Table 2, Pin Characteristics, for typical values.

TABLE 2. PIN CHARACTERISTICS

Symbol	Parameter	Test Conditions	Minimum	Typical	Maximum	Units
C _{IN}	Input Capacitance			4		pF
R _{PULLUP}	Input Pullup Resistor			51		kΩ
R _{PULLDOWN}	Input Pulldown Resistor			51		kΩ

TABLE 3A. CONTROL INPUT FUNCTION TABLE

Inputs			Outputs PLL_SEL = 1 PLL Enable Mode
SEL1	SEL0	Reference Frequency Range (MHz)*	Q0:Q4, nQ0:nQ4
0	0	250 - 700	÷ 1
0	1	125 - 350	÷ 1
1	0	62.5 - 175	÷ 1
1	1	31.25 - 87.5	÷ 1

TABLE 3B. PLL BYPASS FUNCTION TABLE

Inputs		Outputs PLL_SEL = 0 PLL Bypass Mode
SEL1	SEL0	Q0:Q4, nQ0:nQ4
0	0	÷ 4
0	1	÷ 4
1	0	÷ 4
1	1	÷ 8

*NOTE: VCO frequency range for all configurations above is 250MHz to 700MHz.



ABSOLUTE MAXIMUM RATINGS

Supply Voltage, V_{CC}	4.6V
Inputs, V_i	-0.5V to $V_{CC} + 0.5V$
Outputs, I_o	
Continuous Current	50mA
Surge Current	100mA
Package Thermal Impedance, θ_{JA}	
32 Lead LQFP	47.9°C/W (0 lfpm)
32 Lead VFQFN	34.8°C/W (0 lfpm)
Storage Temperature, T_{STG}	-65°C to 150°C

NOTE: Stresses beyond those listed under Absolute Maximum Ratings may cause permanent damage to the device. These ratings are stress specifications only. Functional operation of product at these conditions or any conditions beyond those listed in the *DC Characteristics* or *AC Characteristics* is not implied. Exposure to absolute maximum rating conditions for extended periods may affect product reliability.

TABLE 4A. POWER SUPPLY DC CHARACTERISTICS, $V_{CC} = V_{CCA} = V_{CCO} = 3.3V \pm 5\%$, $T_A = 0^\circ C$ TO $70^\circ C$

Symbol	Parameter	Test Conditions	Minimum	Typical	Maximum	Units
V_{CC}	Core Supply Voltage		3.135	3.3	3.465	V
V_{CCA}	Analog Supply Voltage		3.135	3.3	3.465	V
V_{CCO}	Output Supply Voltage		3.135	3.3	3.465	V
I_{EE}	Power Supply Current				150	mA
I_{CCA}	Analog Supply Current				15	mA

TABLE 4B. LVCMOS/LVTTL DC CHARACTERISTICS, $V_{CC} = V_{CCA} = V_{CCO} = 3.3V \pm 5\%$, $T_A = 0^\circ C$ TO $70^\circ C$

Symbol	Parameter	Test Conditions	Minimum	Typical	Maximum	Units
V_{IH}	Input High Voltage		2		$V_{CC} + 0.3$	V
V_{IL}	Input Low Voltage		-0.3		0.8	V
I_{IH}	Input High Current	SEL0, SEL1, CLK_SEL, MR	$V_{CC} = V_{IN} = 3.465V$		150	μA
		PLL_SEL	$V_{CC} = V_{IN} = 3.465V$		5	μA
I_{IL}	Input Low Current	SEL0, SEL1, CLK_SEL, MR	$V_{CC} = 3.465V, V_{IN} = 0V$	-5		μA
		PLL_SEL	$V_{CC} = 3.465V, V_{IN} = 0V$	-150		μA

TABLE 4C. DIFFERENTIAL DC CHARACTERISTICS, $V_{CC} = V_{CCA} = V_{CCO} = 3.3V \pm 5\%$, $T_A = 0^\circ C$ TO $70^\circ C$

Symbol	Parameter	Test Conditions	Minimum	Typical	Maximum	Units
I_{IH}	Input High Current	CLK0, CLK1, FB_IN	$V_{CC} = V_{IN} = 3.465V$		150	μA
		nCLK0, nCLK1, nFB_IN	$V_{CC} = V_{IN} = 3.465V$		5	μA
I_{IL}	Input Low Current	CLK0, CLK1, FB_IN	$V_{CC} = 3.465V, V_{IN} = 0V$	-5		μA
		nCLK0, nCLK1, nFB_IN	$V_{CC} = 3.465V, V_{IN} = 0V$	-150		μA
V_{PP}	Peak-to-Peak Input Voltage		0.15		1.3	V
V_{CMR}	Common Mode Input Voltage; NOTE 1, 2		$V_{EE} + 0.5$		$V_{CC} - 0.85$	V

NOTE 1: For single ended applications, the maximum input voltage for CLK0, nCLK0 and CLK1, nCLK1 is $V_{CC} + 0.3V$.

NOTE 2: Common mode voltage is defined as V_{IH} .



TABLE 4D. LVPECL DC CHARACTERISTICS, $V_{CC} = V_{CCA} = V_{CCO} = 3.3V \pm 5\%$, $T_A = 0^\circ C$ TO $70^\circ C$

Symbol	Parameter	Test Conditions	Minimum	Typical	Maximum	Units
V_{OH}	Output High Voltage; NOTE 1		$V_{CCO} - 1.4$		$V_{CCO} - 0.7$	V
V_{OL}	Output Low Voltage; NOTE 1		$V_{CCO} - 2.0$		$V_{CCO} - 1.7$	V
V_{SWING}	Peak-to-Peak Output Voltage Swing		0.6		1.0	V

NOTE 1: Outputs terminated with 50Ω to $V_{CCO} - 2V$.

TABLE 5. INPUT FREQUENCY CHARACTERISTICS, $V_{CC} = V_{CCA} = V_{CCO} = 3.3V \pm 5\%$, $T_A = 0^\circ C$ TO $70^\circ C$

Symbol	Parameter	Test Conditions	Minimum	Typical	Maximum	Units
f_{IN}	Input Frequency	CLK0, nCLK0, CLK1, nCLK1	PLL_SEL = 1	31.25	700	MHz
			PLL_SEL = 0		700	MHz

TABLE 6. AC CHARACTERISTICS, $V_{CC} = V_{CCA} = V_{CCO} = 3.3V \pm 5\%$, $T_A = 0^\circ C$ TO $70^\circ C$

Symbol	Parameter	Test Conditions	Minimum	Typical	Maximum	Units
f_{MAX}	Output Frequency				700	MHz
t_{PD}	Propagation Delay; NOTE 1	PLL_SEL = 0V, $f \leq 700MHz$	3.2		4.2	ns
$t(\emptyset)$	PLL Reference Zero Delay; NOTE 2, 4	PLL_SEL = 3.3V	-50	50	150	ps
$t_{sk(o)}$	Output Skew; NOTE 3, 4				25	ps
$f_{jit(cc)}$	Cycle-to-Cycle Jitter; NOTE 4, 6				25	ps
$f_{jit(\theta)}$	Phase Jitter; NOTE 4, 5, 6				± 50	ps
t_L	PLL Lock Time				1	ms
t_R / t_F	Output Rise/Fall Time	20% to 80% @ 50MHz	300		700	ps
odc	Output Duty Cycle		47		53	%

All parameters measured at f_{MAX} unless noted otherwise.

NOTE 1: Measured from the differential input crossing point to the differential output crossing point.

NOTE 2: Defined as the time difference between the input reference clock and the average feedback input signal when the PLL is locked and the input reference frequency is stable.

NOTE 3: Defined as skew between outputs at the same supply voltage and with equal load conditions. Measured at the output differential cross points.

NOTE 4: This parameter is defined in accordance with JEDEC Standard 65.

NOTE 5: Phase jitter is dependent on the input source used.

NOTE 6: Characterized at VCO frequency of 622MHz.



PARAMETER MEASUREMENT INFORMATION

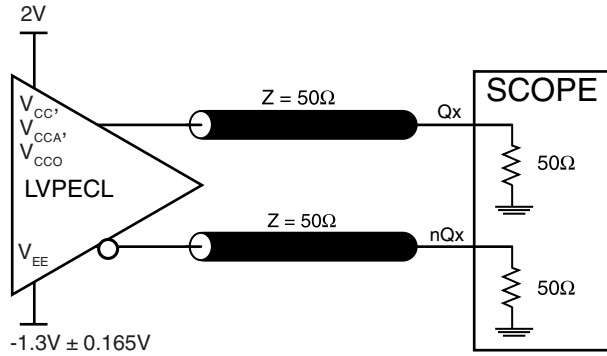

3.3V OUTPUT LOAD AC TEST CIRCUIT

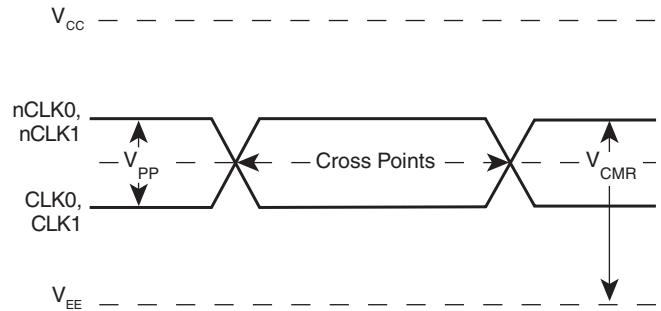

DIFFERENTIAL INPUT LEVEL

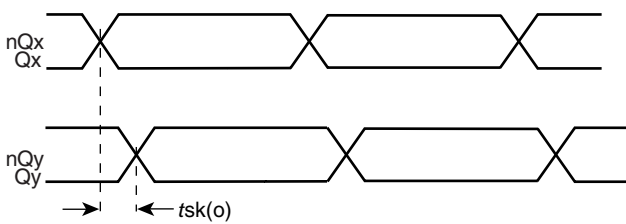

OUTPUT SKEW

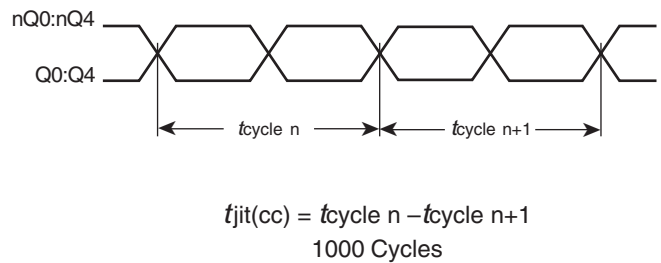

CYCLE-TO-CYCLE JITTER

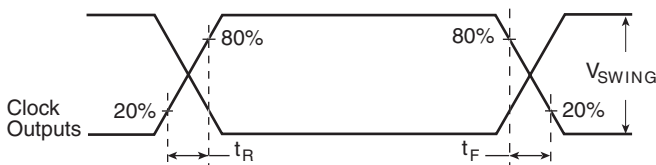

OUTPUT RISE/FALL TIME

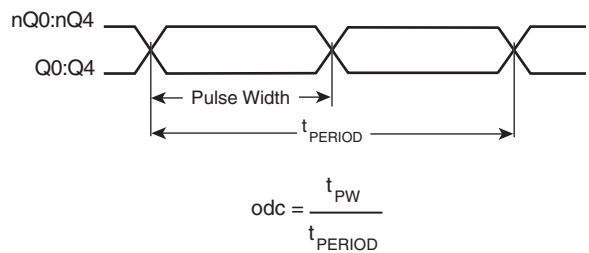

OUTPUT DUTY CYCLE/PULSE WIDTH/PERIOD

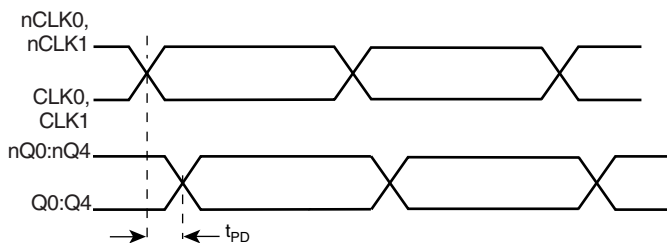

PROPAGATION DELAY

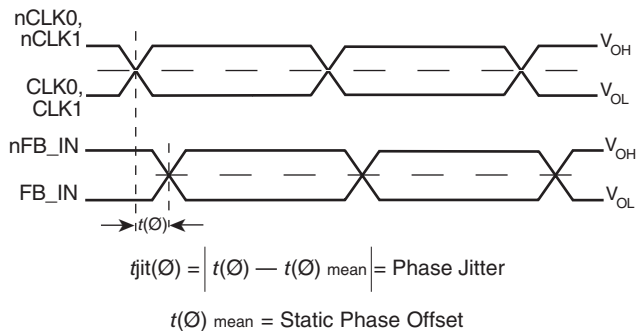

PHASE JITTER & STATIC PHASE OFFSET

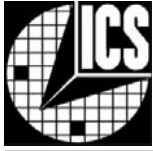

APPLICATION INFORMATION

WIRING THE DIFFERENTIAL INPUT TO ACCEPT SINGLE ENDED LEVELS

Figure 1 shows how the differential input can be wired to accept single ended levels. The reference voltage $V_{REF} \approx V_{CC}/2$ is generated by the bias resistors R1, R2 and C1. This bias circuit should be located as close as possible to the input pin. The ratio

of R1 and R2 might need to be adjusted to position the V_{REF} in the center of the input voltage swing. For example, if the input clock swing is only 2.5V and $V_{CC} = 3.3V$, V_{REF} should be 1.25V and $R2/R1 = 0.609$.

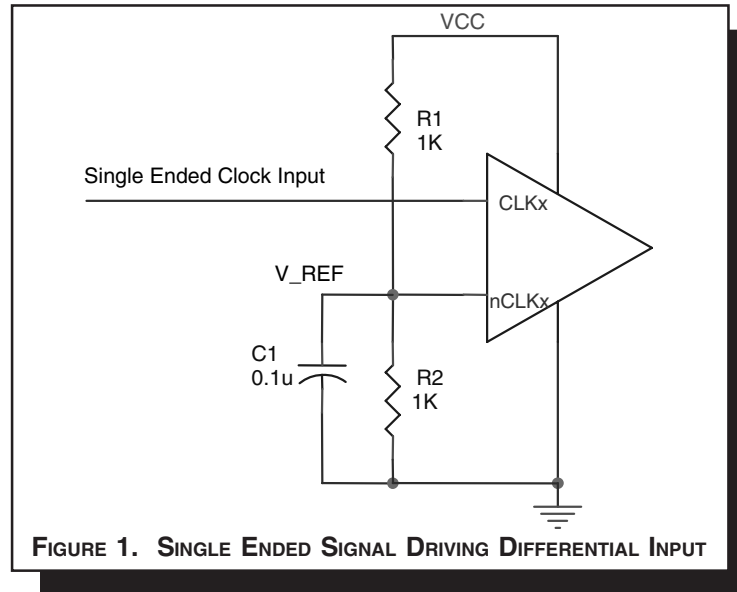

TERMINATION FOR LVPECL OUTPUTS

The clock layout topology shown below is a typical termination for LVPECL outputs. The two different layouts mentioned are recommended only as guidelines.

FOUT and nFOUT are low impedance follower outputs that generate ECL/LVPECL compatible outputs. Therefore, terminating resistors (DC current path to ground) or current sources must be used for functionality. These outputs are designed to drive

50Ω transmission lines. Matched impedance techniques should be used to maximize operating frequency and minimize signal distortion. Figures 2A and 2B show two different layouts which are recommended only as guidelines. Other suitable clock layouts may exist and it would be recommended that the board designers simulate to guarantee compatibility across all printed circuit and clock component process variations.

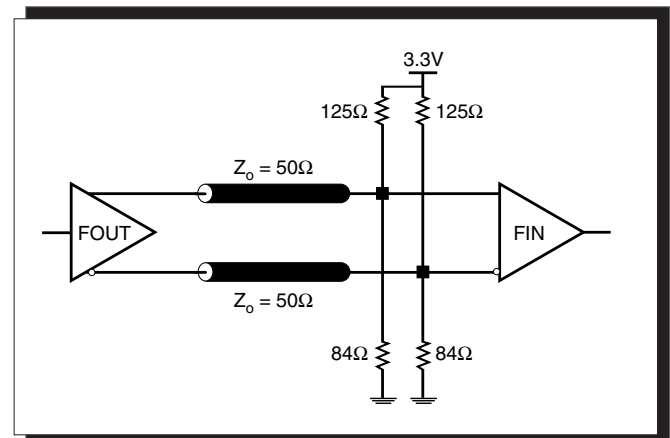
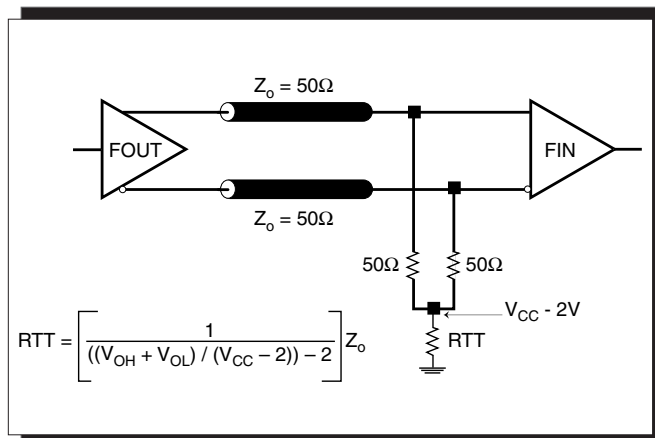



POWER SUPPLY FILTERING TECHNIQUES

As in any high speed analog circuitry, the power supply pins are vulnerable to random noise. The ICS8634-01 provides separate power supplies to isolate any high switching noise from the outputs to the internal PLL. V_{CC} , V_{CCA} , and V_{CCO} should be individually connected to the power supply plane through vias, and bypass capacitors should be used for each pin. To achieve optimum jitter performance, power supply isolation is required. *Figure 3* illustrates how a 10Ω resistor along with a $10\mu\text{F}$ and a $.01\mu\text{F}$ bypass capacitor should be connected to each V_{CCA} pin.

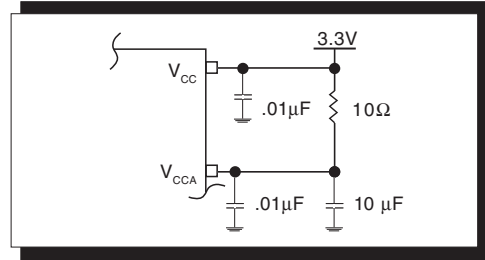

FIGURE 3. POWER SUPPLY FILTERING

DIFFERENTIAL CLOCK INPUT INTERFACE

The CLK/nCLK accepts LVDS, LVPECL, LVHSTL, SSTL, HCSL and other differential signals. Both V_{SWING} and V_{OH} must meet the V_{PP} and V_{CMR} input requirements. Figures 4A to 4D show interface examples for the HiPerClockS CLK/nCLK input driven by the most common driver types. The input interfaces suggested

here are examples only. Please consult with the vendor of the driver component to confirm the driver termination requirements. For example in *Figure 4A*, the input termination applies for ICS HiPerClockS LVHSTL drivers. If you are using an LVHSTL driver from another vendor, use their termination recommendation.

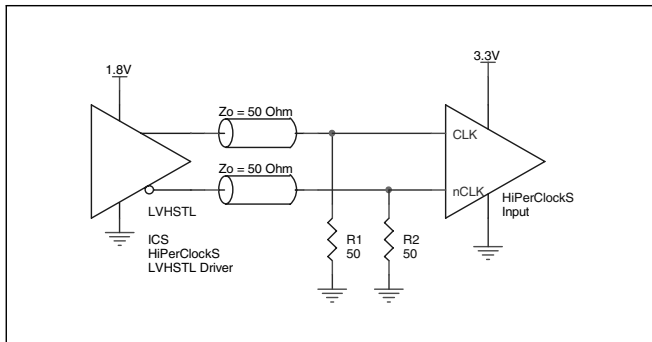

FIGURE 4A. HiPerClockS CLK/nCLK INPUT DRIVEN BY ICS HiPerClockS LVHSTL DRIVER

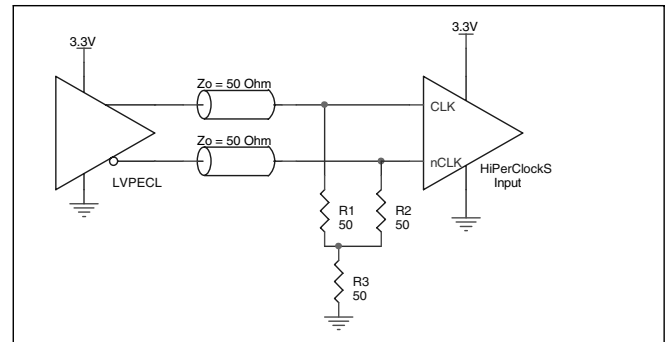

FIGURE 4B. HiPerClockS CLK/nCLK INPUT DRIVEN BY 3.3V LVPECL DRIVER

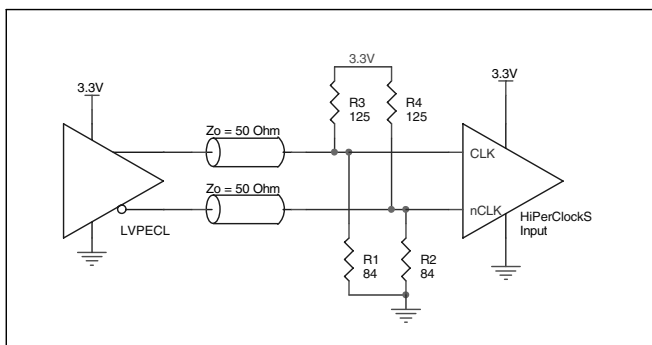

FIGURE 4C. HiPerClockS CLK/nCLK INPUT DRIVEN BY 3.3V LVPECL DRIVER

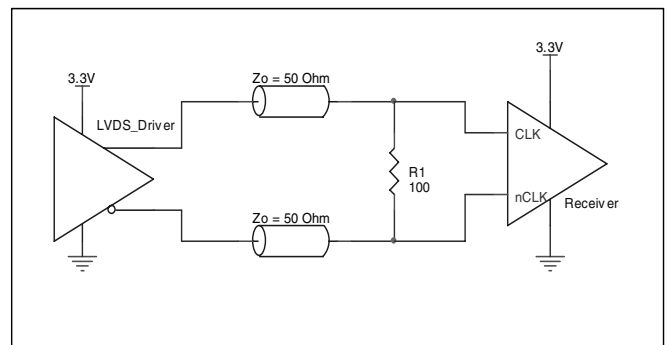

FIGURE 4D. HiPerClockS CLK/nCLK INPUT DRIVEN BY 3.3V LVDS DRIVER



LAYOUT GUIDELINE

The schematic of the ICS8634-01 layout example is shown in *Figure 5A*. The ICS8634-01 recommended PCB board layout for this example is shown in *Figure 5B*. This layout example is used as a general guideline. The layout in the actual system will

depend on the selected component types, the density of the components, the density of the traces, and the stack up of the P.C. board.

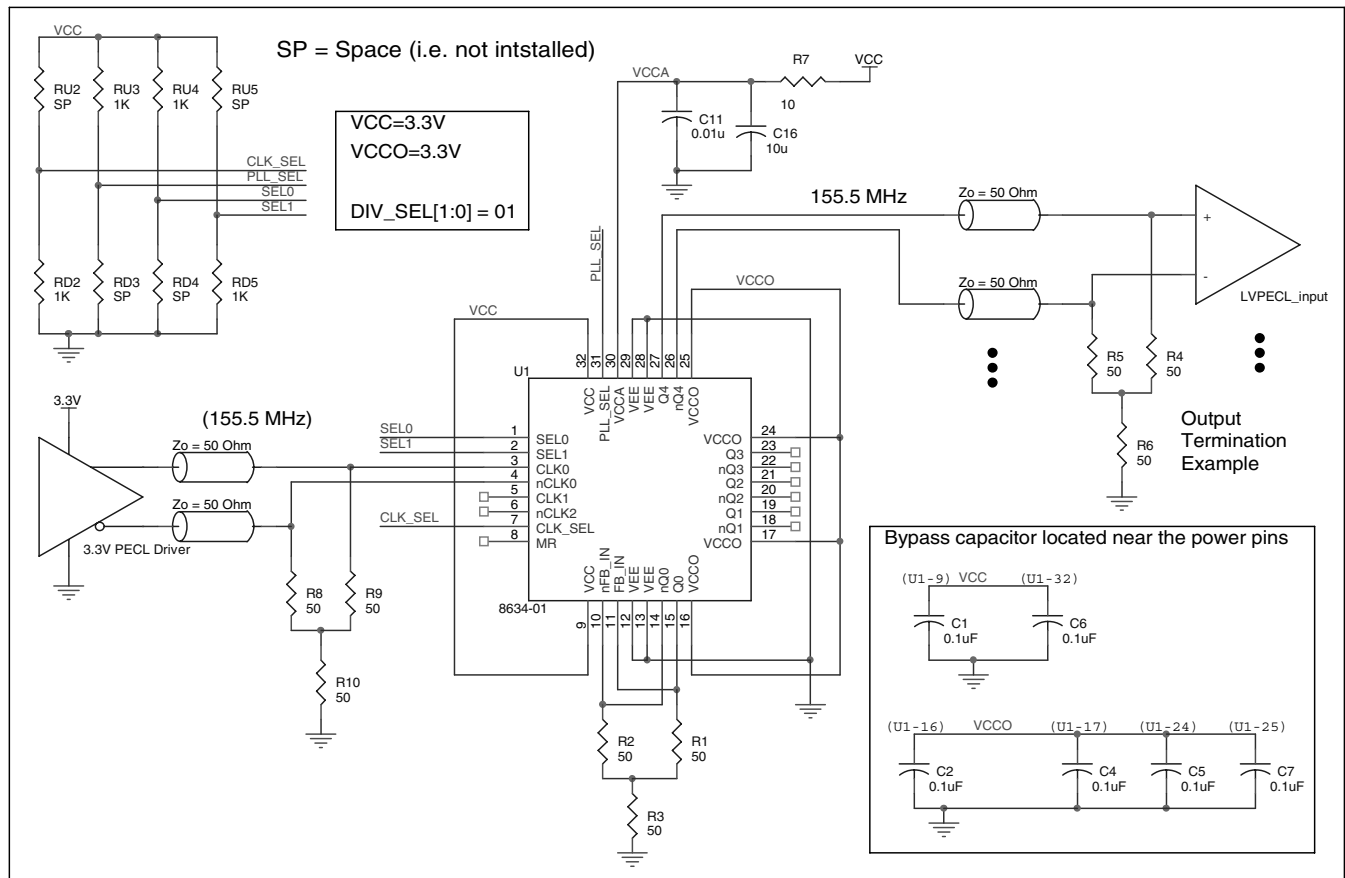

FIGURE 5A. ICS8634-01 LVPECL ZERO DELAY BUFFER SCHEMATIC EXAMPLE



The following component footprints are used in this layout example:

All the resistors and capacitors are size 0603.

POWER AND GROUNDING

Place the decoupling capacitors C1, C2, C4, C5, C6, and C7, as close as possible to the power pins. If space allows, placement of the decoupling capacitor on the component side is preferred. This can reduce unwanted inductance between the decoupling capacitor and the power pin caused by the via.

Maximize the power and ground pad sizes and number of vias capacitors. This can reduce the inductance between the power and ground planes and the component power and ground pins.

The RC filter consisting of R7, C11, and C16 should be placed as close to the V_{CCA} pin as possible.

CLOCK TRACES AND TERMINATION

Poor signal integrity can degrade the system performance or cause system failure. In synchronous high-speed digital systems, the clock signal is less tolerant to poor signal integrity than other signals. Any ringing on the rising or falling edge or excessive ring back can cause system failure. The shape of the trace and the

trace delay might be restricted by the available space on the board and the component location. While routing the traces, the clock signal traces should be routed first and should be locked prior to routing other signal traces.

- The differential 50Ω output traces should have same length.
- Avoid sharp angles on the clock trace. Sharp angle turns cause the characteristic impedance to change on the transmission lines.
- Keep the clock traces on the same layer. Whenever possible, avoid placing vias on the clock traces. Placement of vias on the traces can affect the trace characteristic impedance and hence degrade signal integrity.
- To prevent cross talk, avoid routing other signal traces in parallel with the clock traces. If running parallel traces is unavoidable, allow a separation of at least three trace widths between the differential clock trace and the other signal trace.
- Make sure no other signal traces are routed between the clock trace pair.
- The matching termination resistors should be located as close to the receiver input pins as possible.

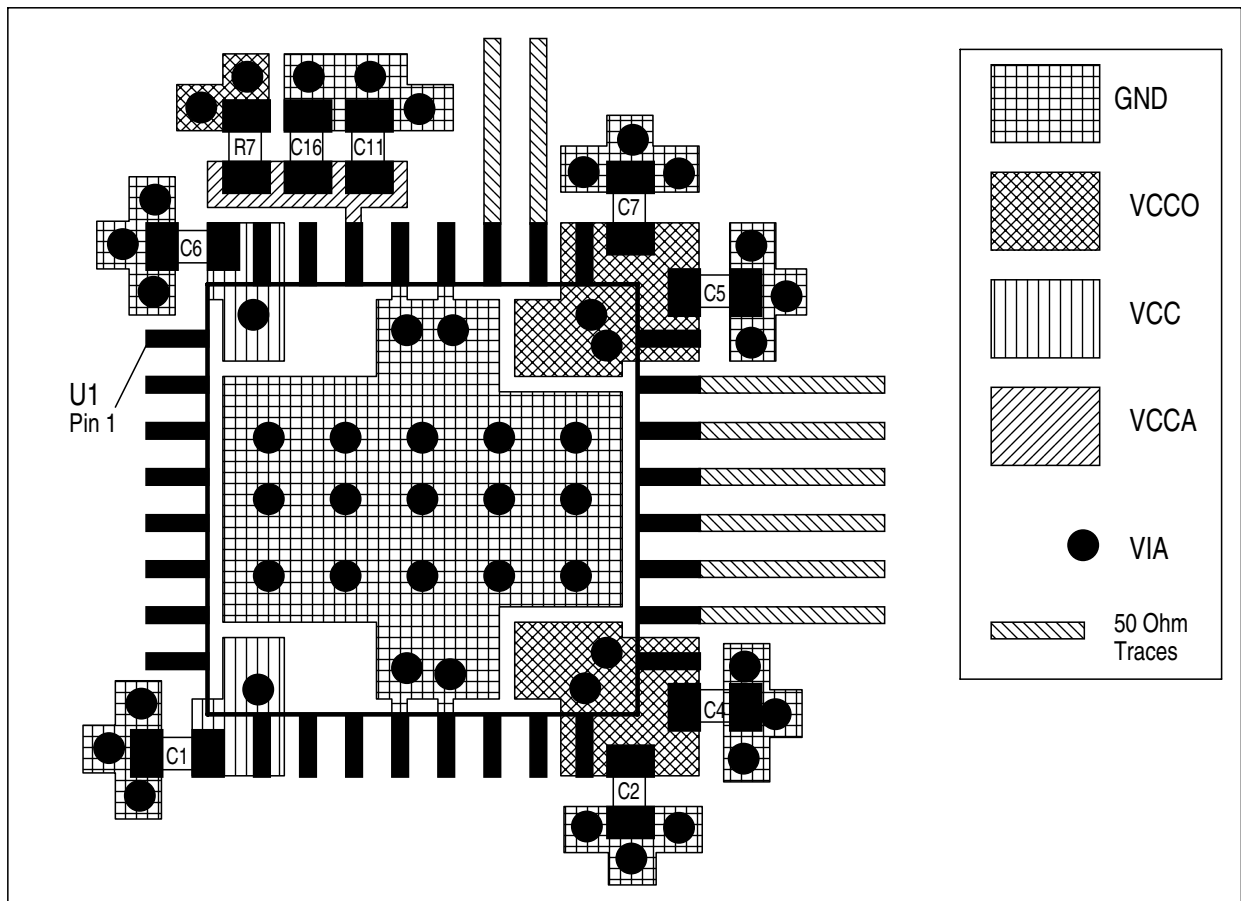

FIGURE 5B. PCB BOARD LAYOUT FOR ICS8634-01



POWER CONSIDERATIONS

This section provides information on power dissipation and junction temperature for the ICS8634-01. Equations and example calculations are also provided.

1. Power Dissipation.

The total power dissipation for the ICS8634-01 is the sum of the core power plus the power dissipated in the load(s). The following is the power dissipation for $V_{CC} = 3.3V + 5\% = 3.465V$, which gives worst case results.

NOTE: Please refer to Section 3 for details on calculating power dissipated in the load.

- Power (core)_{MAX} = $V_{CC_MAX} * I_{EE_MAX} = 3.465V * 150mA = 520mW$
- Power (outputs)_{MAX} = **30mW/Loaded Output pair**
If all outputs are loaded, the total power is $5 * 30mW = 150mW$

$$\text{Total Power}_{MAX} (3.465V, \text{ with all outputs switching}) = 520mW + 150mW = 670mW$$

2. Junction Temperature.

Junction temperature, T_j , is the temperature at the junction of the bond wire and bond pad and directly affects the reliability of the device. The maximum recommended junction temperature for HiPerClockS™ devices is 125°C.

The equation for T_j is as follows: $T_j = \theta_{JA} * Pd_{total} + T_A$

T_j = Junction Temperature

θ_{JA} = Junction-to-Ambient Thermal Resistance

Pd_{total} = Total Device Power Dissipation (example calculation is in section 1 above)

T_A = Ambient Temperature

In order to calculate junction temperature, the appropriate junction-to-ambient thermal resistance θ_{JA} must be used. Assuming a moderate air flow of 200 linear feet per minute and a multi-layer board, the appropriate value is 42.1°C/W per Table 7A below.

Therefore, T_j for an ambient temperature of 70°C with all outputs switching is:

$$70^\circ C + 0.670W * 42.1^\circ C/W = 98.2^\circ C. \text{ This is well below the limit of } 125^\circ C.$$

This calculation is only an example. T_j will obviously vary depending on the number of loaded outputs, supply voltage, air flow, and the type of board (single layer or multi-layer).

TABLE 7A. THERMAL RESISTANCE θ_{JA} FOR 32-PIN LQFP, FORCED CONVECTION

θ_{JA} by Velocity (Linear Feet per Minute)			
	0	200	500
Single-Layer PCB, JEDEC Standard Test Boards	67.8°C/W	55.9°C/W	50.1°C/W
Multi-Layer PCB, JEDEC Standard Test Boards	47.9°C/W	42.1°C/W	39.4°C/W

NOTE: Most modern PCB designs use multi-layered boards. The data in the second row pertains to most designs.

TABLE 7B. θ_{JA} VS. AIR FLOW TABLE FOR 32 LEAD VFQFN PACKAGE

θ_{JA} 0 Air Flow (Linear Feet per Minute)	
	0
Multi-Layer PCB, JEDEC Standard Test Boards	34.8°C/W



3. Calculations and Equations.

The purpose of this section is to derive the power dissipated into the load.

LVPECL output driver circuit and termination are shown in Figure 6.

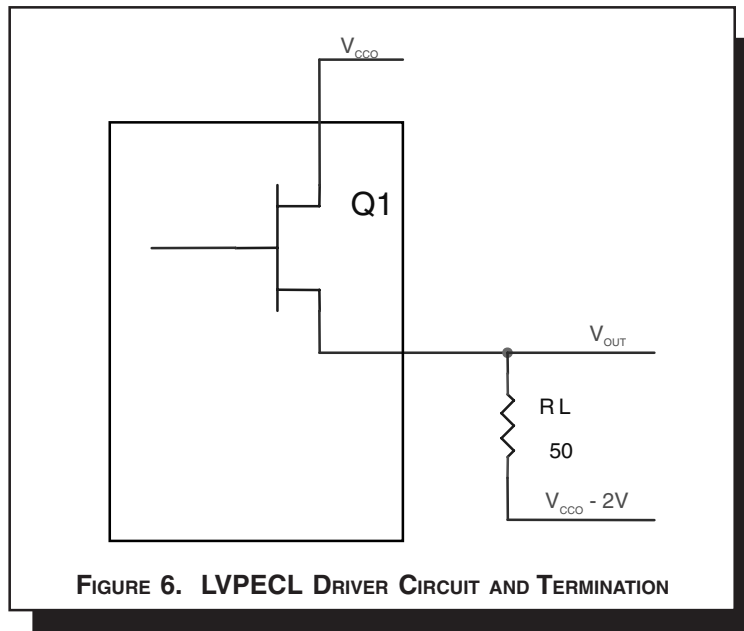

FIGURE 6. LVPECL DRIVER CIRCUIT AND TERMINATION

To calculate worst case power dissipation into the load, use the following equations which assume a 50Ω load, and a termination voltage of $V_{CCO} - 2V$.

- For logic high, $V_{OUT} = V_{OH_MAX} = V_{CCO_MAX} - 0.9V$

$$(V_{CCO_MAX} - V_{OH_MAX}) = 0.9V$$

- For logic low, $V_{OUT} = V_{OL_MAX} = V_{CCO_MAX} - 1.7V$

$$(V_{CCO_MAX} - V_{OL_MAX}) = 1.7V$$

Pd_H is power dissipation when the output drives high.

Pd_L is the power dissipation when the output drives low.

$$Pd_H = [(V_{OH_MAX} - (V_{CCO_MAX} - 2V))/R_L] * (V_{CCO_MAX} - V_{OH_MAX}) = [(2V - (V_{CCO_MAX} - V_{OH_MAX}))/R_L] * (V_{CCO_MAX} - V_{OH_MAX}) = [(2V - 0.9V)/50\Omega] * 0.9V = 19.8mW$$

$$Pd_L = [(V_{OL_MAX} - (V_{CCO_MAX} - 2V))/R_L] * (V_{CCO_MAX} - V_{OL_MAX}) = [(2V - (V_{CCO_MAX} - V_{OL_MAX}))/R_L] * (V_{CCO_MAX} - V_{OL_MAX}) = [(2V - 1.7V)/50\Omega] * 1.7V = 10.2mW$$

Total Power Dissipation per output pair = $Pd_H + Pd_L = 30mW$



RELIABILITY INFORMATION

TABLE 8A. θ_{JA} VS. AIR FLOW TABLE FOR 32 LQFP

θ_{JA} by Velocity (Linear Feet per Minute)			
	0	200	500
Single-Layer PCB, JEDEC Standard Test Boards	67.8°C/W	55.9°C/W	50.1°C/W
Multi-Layer PCB, JEDEC Standard Test Boards	47.9°C/W	42.1°C/W	39.4°C/W

NOTE: Most modern PCB designs use multi-layered boards. The data in the second row pertains to most designs.

TABLE 8B. θ_{JA} VS. AIR FLOW TABLE FOR 32 LEAD VFQFN PACKAGE

θ_{JA} 0 Air Flow (Linear Feet per Minute)	
	0
Multi-Layer PCB, JEDEC Standard Test Boards	34.8C/W

TRANSISTOR COUNT

The transistor count for ICS8634-01 is: 2969



PACKAGE OUTLINE - Y SUFFIX FOR 32 LEAD LQFP

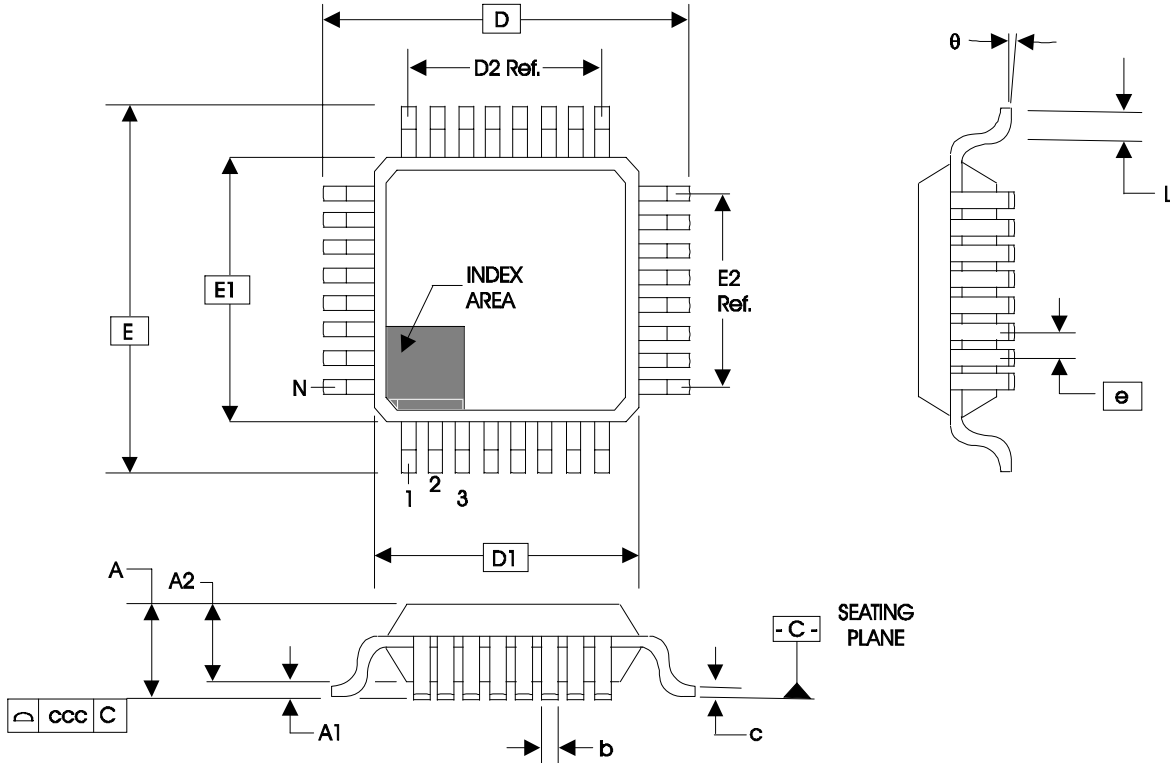
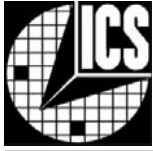

TABLE 9. PACKAGE DIMENSIONS

JEDEC VARIATION ALL DIMENSIONS IN MILLIMETERS			
SYMBOL	BBA		
	MINIMUM	NOMINAL	MAXIMUM
N	32		
A			1.60
A1	0.05		0.15
A2	1.35	1.40	1.45
b	0.30	0.37	0.45
c	0.09		0.20
D		9.00 BASIC	
D1		7.00 BASIC	
D2		5.60	
E		9.00 BASIC	
E1		7.00 BASIC	
E2		5.60	
e		0.80 BASIC	
L	0.45	0.60	0.75
theta	0°		7°
ccc			0.10

Reference Document: JEDEC Publication 95, MS-026



PACKAGE OUTLINE - K SUFFIX FOR 32 LEAD VFQFN

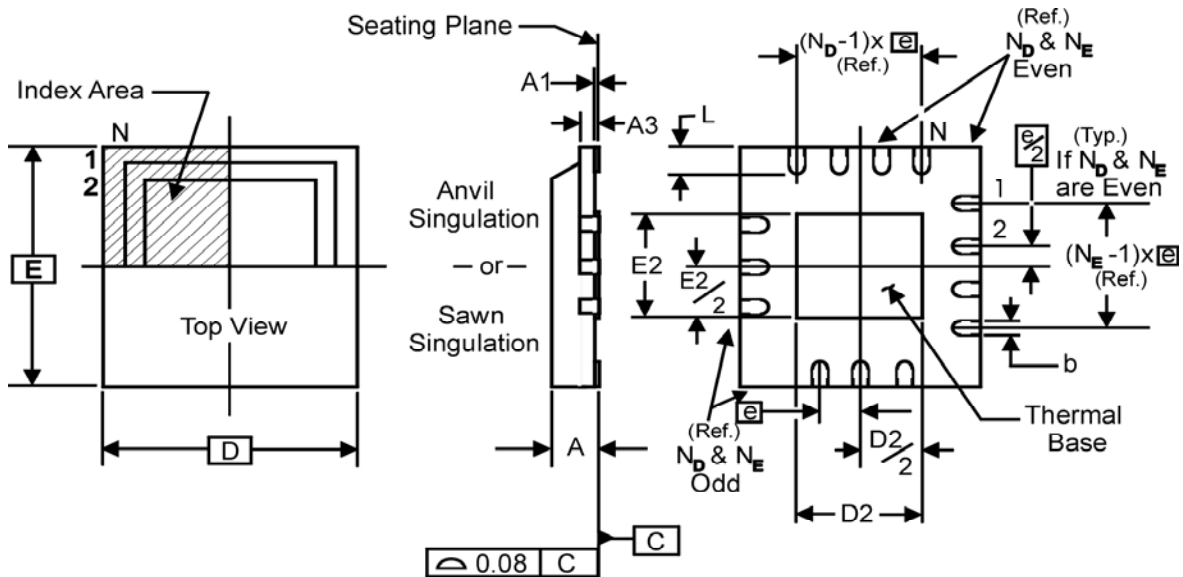

TABLE 9B. PACKAGE DIMENSIONS

JEDEC VARIATION ALL DIMENSIONS IN MILLIMETERS		
SYMBOL	MINIMUM	MAXIMUM
N	32	
A	0.80	1.0
A1	0	0.05
A3	0.25 Reference	
b	0.18	0.30
e	0.50 BASIC	
N_D	8	
N_E	8	
D	5.0	
D2	1.25	3.25
E	5.0	
E2	1.25	3.25
L	0.30	0.50

Reference Document: JEDEC Publication 95, MO-220



TABLE 10. ORDERING INFORMATION

Part/Order Number	Marking	Package	Shipping Packaging	Temperature
ICS8634BY-01	ICS8634BY-01	32 Lead LQFP	Tray	0°C to 70°C
ICS8634BY-01T	ICS8634BY-01	32 Lead LQFP	1000 Tape & Reel	0°C to 70°C
ICS8634BY-01LF	ICS8634BY01L	32 Lead "Lead-Free" LQFP	Tray	0°C to 70°C
ICS8634BY-01LFT	ICS8634BY01L	32 Lead "Lead-Free" LQFP	1000 Tape & Reel	0°C to 70°C
ICS8634BK-01	ICS8634BK01	32 Lead VFQFN	Tray	0°C to 70°C
ICS8634BK-01T	ICS8634BK01	32 Lead VFQFN	2500 Tape & Reel	0°C to 70°C
ICS8634BK-01LF	TBD	32 Lead "Lead-Free" VFQFN	Tray	0°C to 70°C
ICS8634BK-01LFT	TBD	32 Lead "Lead-Free" VFQFN	2500 Tape & Reel	0°C to 70°C

NOTE: Parts that are ordered with an "LF" suffix to the part number are the Pb-Free configuration and are RoHS compliant.

The aforementioned trademark, HiPerClockS™ is a trademark of Integrated Circuit Systems, Inc. or its subsidiaries in the United States and/or other countries. While the information presented herein has been checked for both accuracy and reliability, Integrated Circuit Systems, Incorporated (ICS) assumes no responsibility for either its use or for infringement of any patents or other rights of third parties, which would result from its use. No other circuits, patents, or licenses are implied. This product is intended for use in normal commercial applications. Any other applications such as those requiring extended temperature range, high reliability, or other extraordinary environmental requirements are not recommended without additional processing by ICS. ICS reserves the right to change any circuitry or specifications without notice. ICS does not authorize or warrant any ICS product for use in life support devices or critical medical instruments.



REVISION HISTORY SHEET				
Rev	Table	Page	Description of Change	Date
A		1	Updated Block Diagram.	11/2/01
A	T3A T6	3 5	Added note at bottom of the table. Added Note 6.	11/20/01
A		9	Added Termination for LVPECL Outputs and Power Supply Filtering Techniques sections.	6/3/02
A	T1	2 6 8 14	Pin Description table - revised MR description. 3.3V Output Load Test Circuit Diagram - revised VEE equation from ± 0.135 to ± 0.165 . Updated Output Rise/Fall Time Diagram. Power Considerations/Calculations & Equations - updated power dissipation equations.	8/22/02
B	T1 T4A T4D	2 3 4 6	Revised MR and V_{CC} pin descriptions. V_{CC} Parameter replaced Positive Supply Voltage with Core Supply Voltage. Changed V_{SWING} (max) limit from 900mV to 1.0V. Updated Fig. 1, Single Ended Signal Driving Differential Input and LVPECL Output Termination Diagrams. Updated format.	3/5/03
C	T2 T6	2 3 4 6 7	Pin Characteristics Table - changed C_{IN} 4pF max. to 4pF typical. Absolute Maximum Ratings - updated Outputs. AC Characteristics Table - modified t_{PD} limit from 3.6ns min. to 3.2ns min. and deleted 3.9ns typical. Updated LVPECL Output Termination drawings. Added Differential Clock Input Interface section.	8/26/04
C	T10	14	Ordering Information Table - added Lead-Free part number.	10/15/04
C			Add 32 Lead VFQFN package throughout data sheet.	11/12/04
D	T4D T10	4 10 - 11 15	LVPECL DC Characteristics Table -corrected V_{OH} max. from $V_{CCO} - 1.0V$ to $V_{CCO} - 0.9V$. Power Considerations - corrected power dissipation to reflect V_{OH} max in Table 4D. Ordering Information Table - added lead-free part/order number for ICS8634BK-01 and added lead-free note.	4/12/07